



Stella™ Sliding Door Lock

Installation Instructions For All Models

Pack Contents

Main Fixtures

- 1. Internal Handle x1
- 2. External Pull x1
- 3. Lock Body x1
- 4. Internal Cylinder x1
- 5. External Cylinder x1
- 6. Striker Body x1
- 7. Striker Cover x1
- 8. Locator Template x1
- 9. Hole Template x1

Screw Fixings

- 10. M4x50 Tapitite screw x2
- M4x40 Tapitite screw x2
- 11. M4x20 c/s screw x2
- 12. No7x10 screw x2
- 13. No7x25 screw x2
- 14. 8x1/2 pozi screw x2
- 15. M3x8.0 pozi screw x2

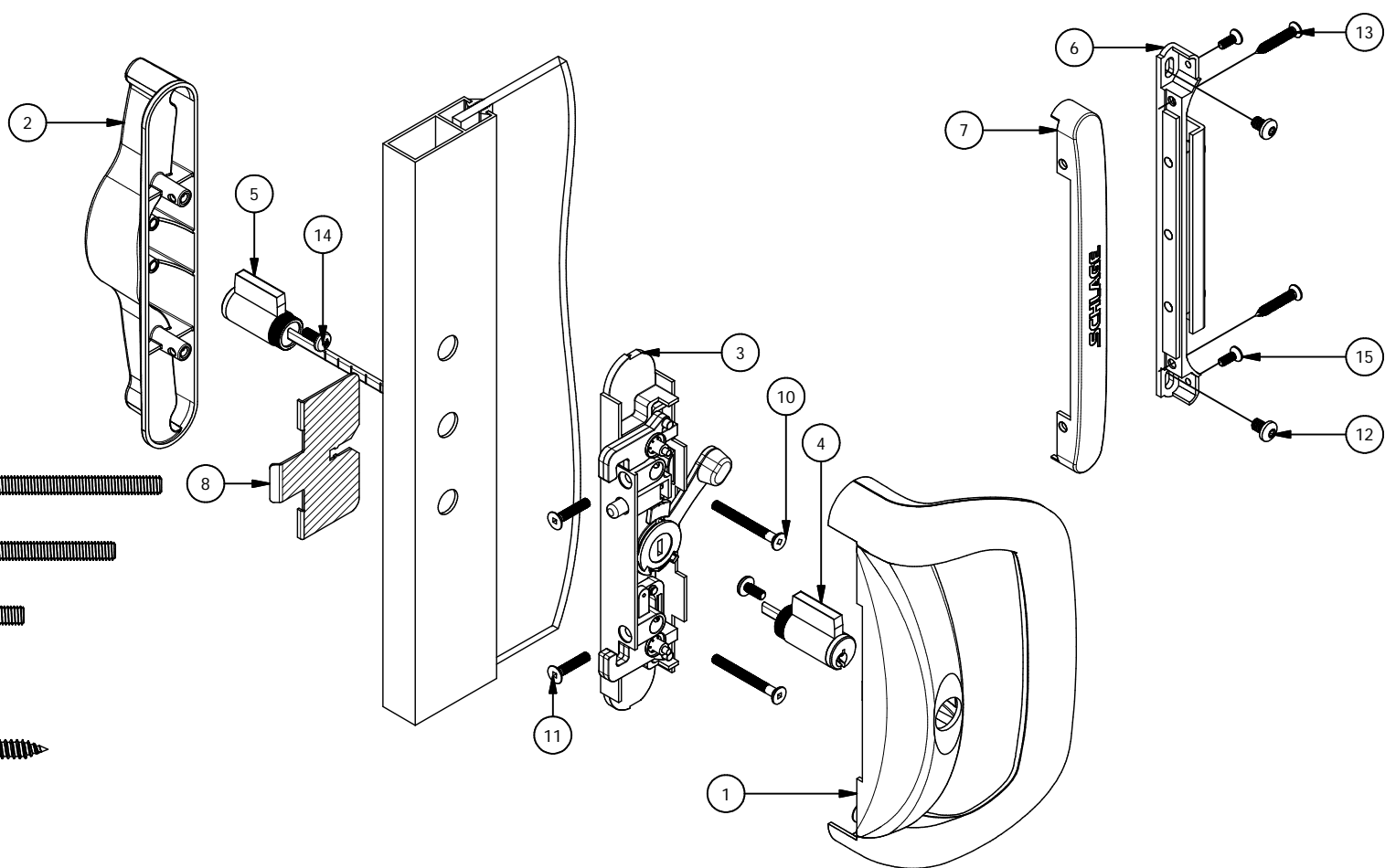

Step 1: Door Preparation

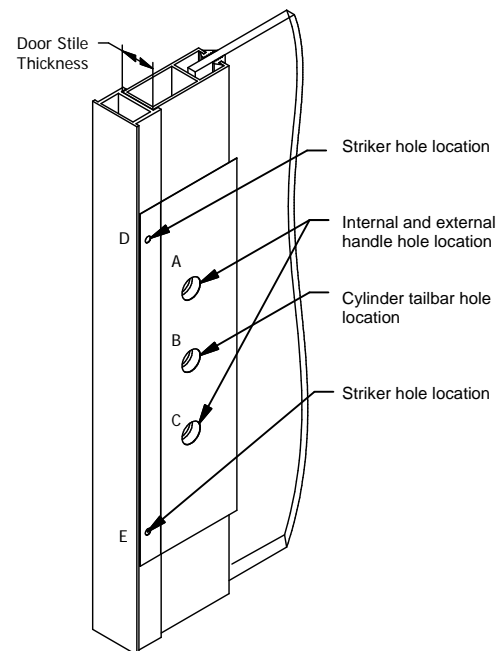

- 1 Remove hole template ⑨ from installation instructions
- 2 Locate hole template ⑨ onto fully closed internal door. Dotted lines must line up with fixed door frame front edge.
- 3 Mark holes A, B, C, D, and E.
- 4 Drill holes A, B, and C with 12mm drill. Drill holes D and E with 3.5mm.

Step 2: Cylinder Preparation for Locking And Deadlocking models only

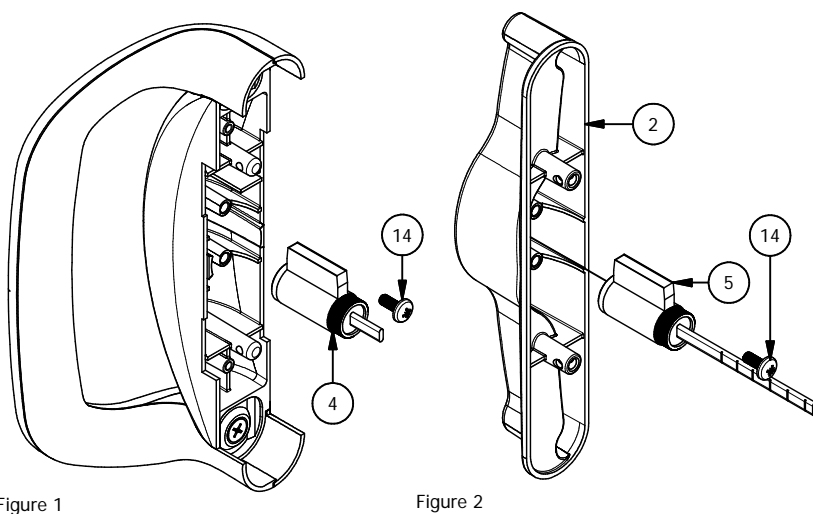

- Figure 1:
Internal Handle ① rear view showing placement of internal cylinder ④ and screw fixing ⑭.
- Figure 2:
External pull ② rear view showing placement of external cylinder ⑤ and screw fixing ⑭.
- Note: Cylinders can be handed for left or right opening doors,
1 Remove screw ⑭ and extract cylinder if necessary.
2 Rotate and relocate cylinder according to handing, re secure with screw.

Step 3: Cylinder Tailbar Adjustment

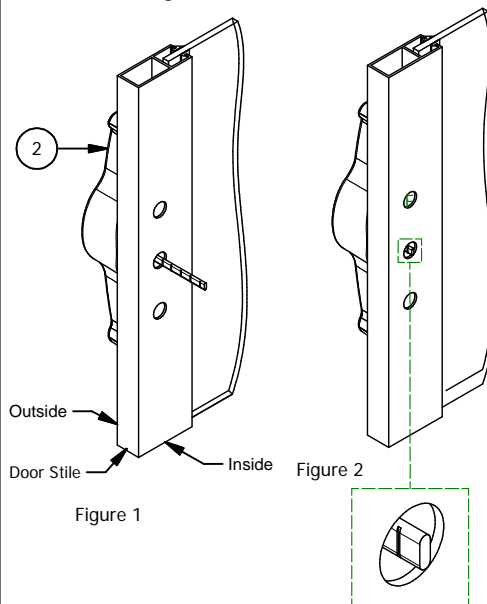

- 1 Locate external pull ② onto outside of stile with tailbar showing through to inside.
- 2 Measure thickness of aluminium door stile (Figure 1) and cut tailbar to match door stile thickness in (Figure 2)

⑨ Template

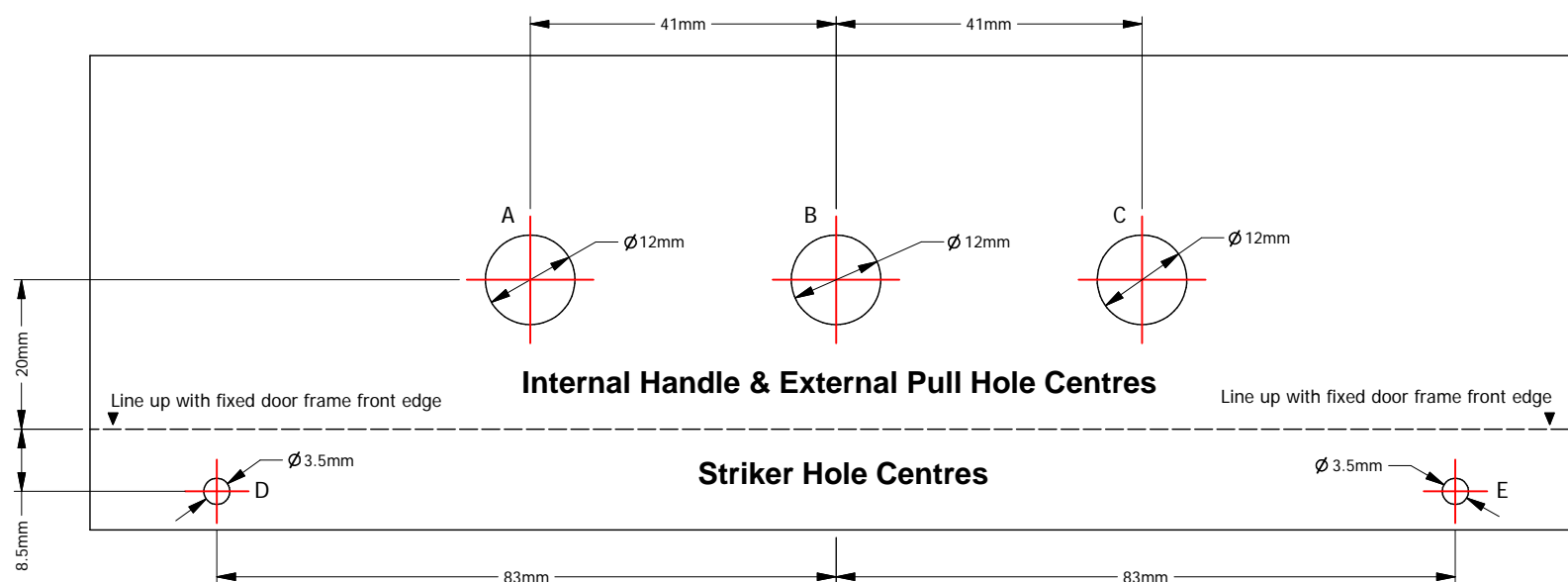

Step 4: External Pull & Lock Body Fixing

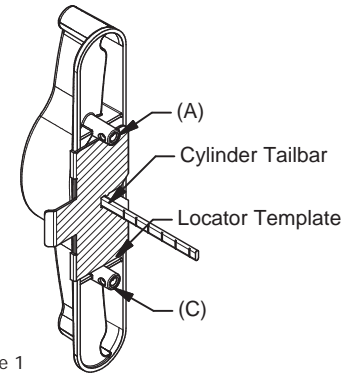
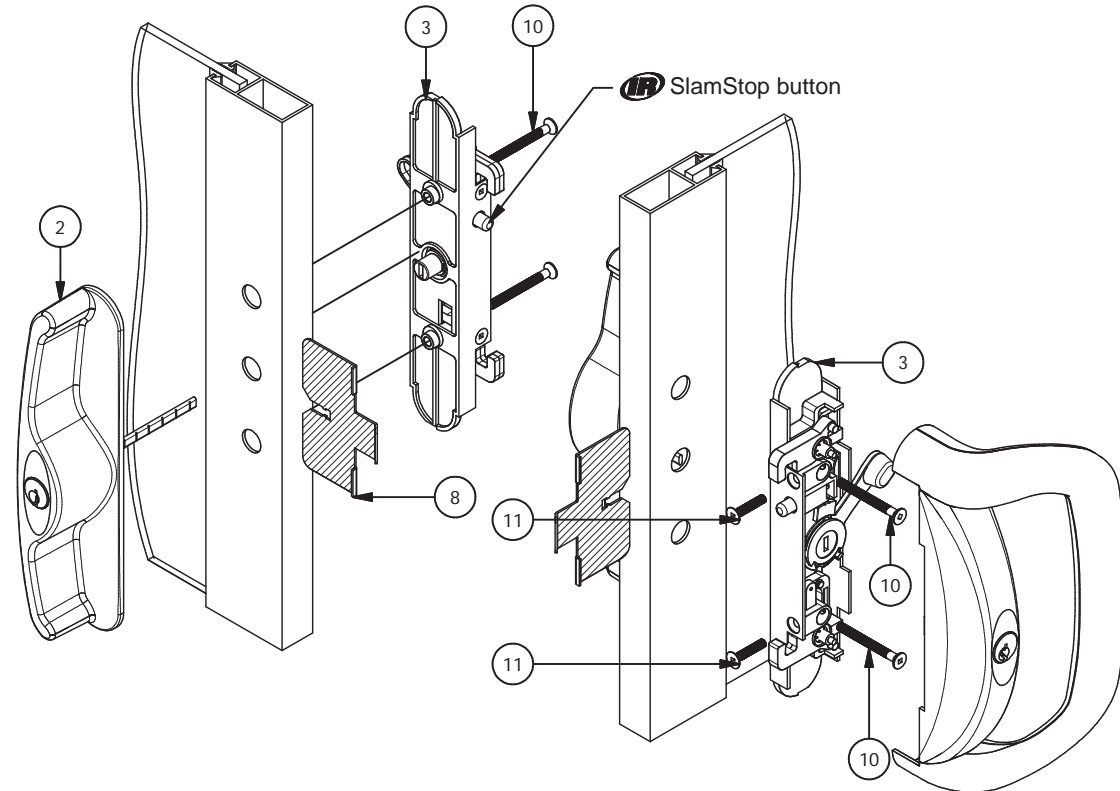
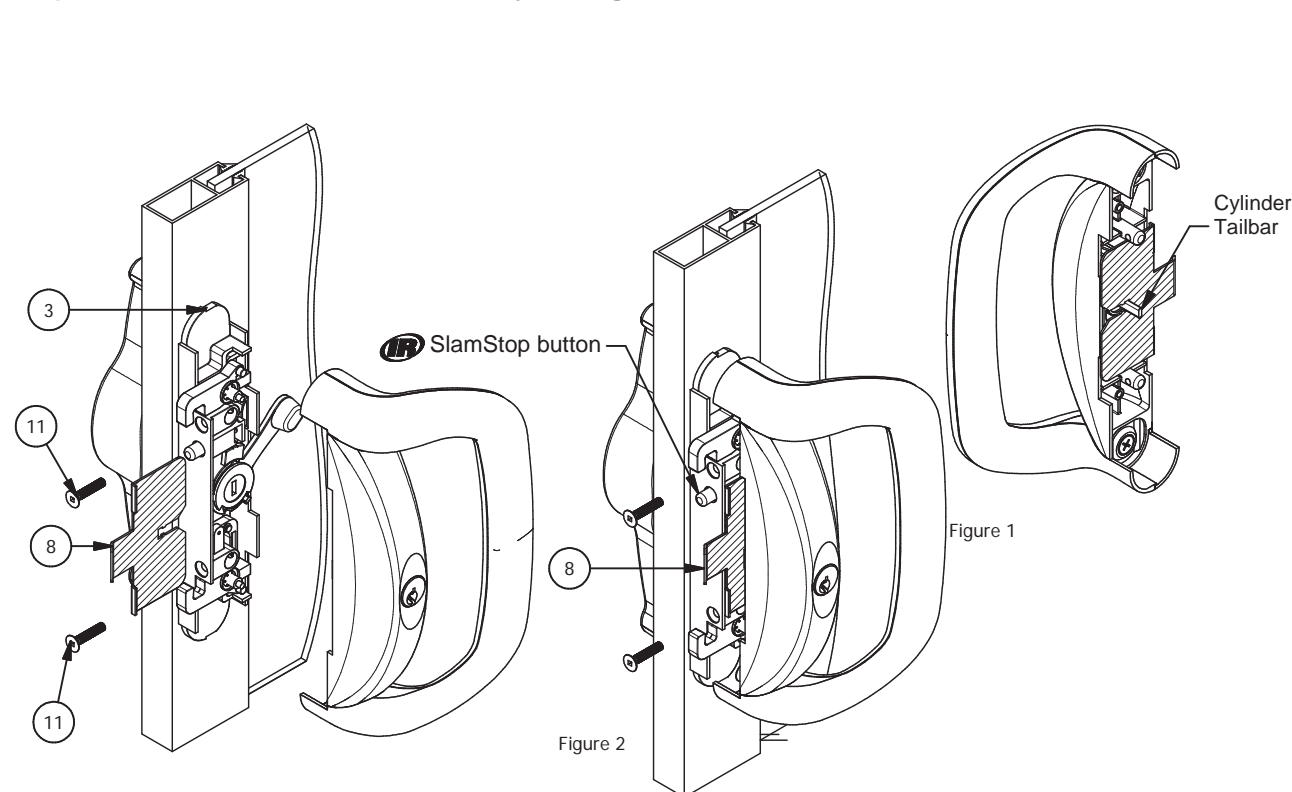

Figure 1

- 1 Remove internal handle ① from lock body ③ by removing screw fixings ⑪
- 2 Locate external pull ② to external side of sliding door. For locking and deadlocking models only, ensure the cylinder tailbar is in a vertical position.
- 3 Locate lock body ③ to inside of sliding door. For locking and deadlocking models only, you must first depress the slamstop button and activate the snib to throw the locking jaws out before mounting to the stile. Secure lock body ③ to external pull ② with correct length taprite screws ⑩ provided.
- 4 To assist with engaging the cylinder tailbar into the lock body ③ use the locator template ⑧. Simply slide the locator template ⑧ between fixing posts (A) and (C) until it engages fully with the cylinder tailbar. See (Figure 1)

Note: Remove Locator template ⑧ before securing Lock body ③ to external pull ②

Step 5: Internal Handle To Lock Body Fixing



- 1 Locate internal handle ① onto lock body ③ and secure with fixings provided.
- 2 For deadlocking models only, ensure the cylinder tailbar is in a vertical position before attaching to lock body ③.
- 3 To assist with engaging the cylinder tailbar into the lock body use the locator template ⑧. Simply slide the locator template ⑧ between fixing posts (A) and (C) until it engages fully with the cylinder tailbar. See (Figure 1)

Note: Remove locator template ⑧ before securing internal handle ① to lock body ③

- 4 Check general locking function by first depressing slamstop button and activating snib to retract jaws to the unlock position. For deadlocking models only depress slamstop button and rotate key clockwise to check retraction of jaws, Turn key counter clockwise until a full stop position is felt to engage deadlocking function - snib is now in-operable. To deactivate deadlocking function rotate key clockwise to a full stop position is felt - snib is now operable. For both functions, key must be rotated back to vertical position to be removed.

Note: Figure 2 shows right hand internal handle. For left hand internal deadlocking models, check general locking function by reversing steps detailed in step 4 above

Step 6: Strike Installation

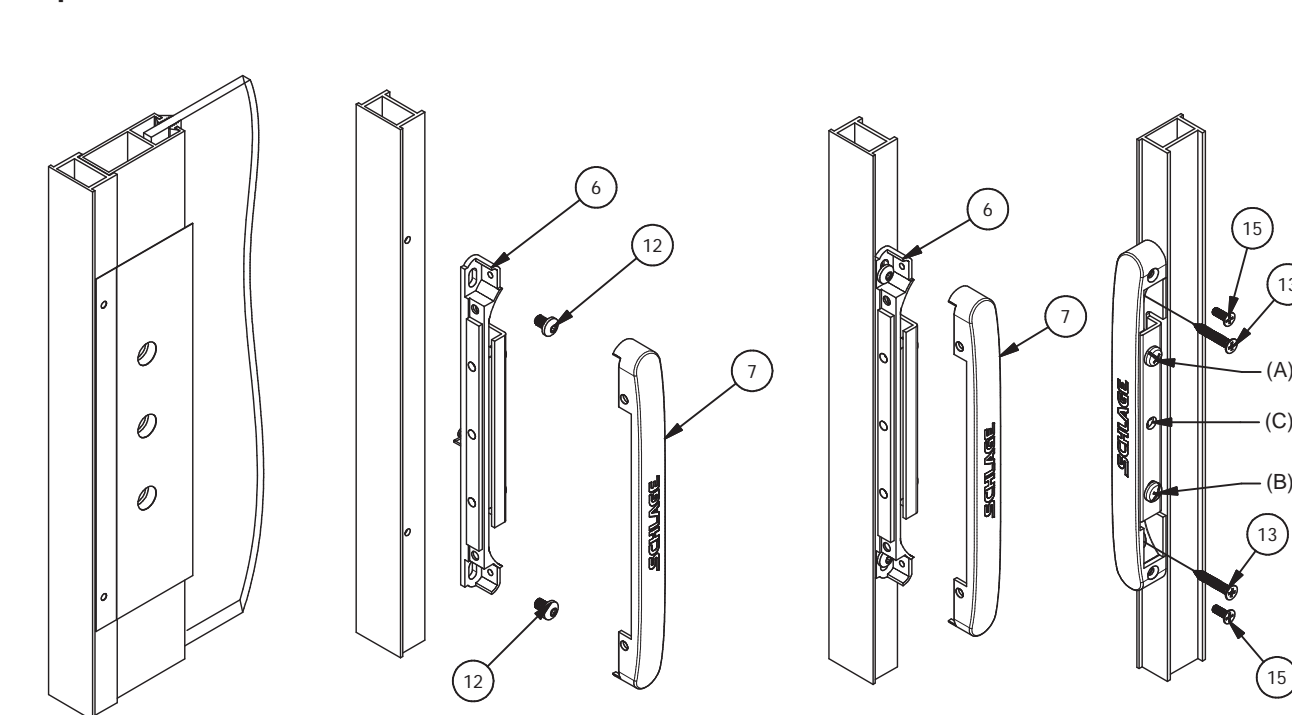

- 1 Remove striker cover ⑦ from strike body ⑥.
- 2 Locate strike body ⑥ onto door frame and secure with screw fixings ⑫ provided.
- 3 Check strike body ⑥ is centred on the lock body ③. Adjust position if necessary by unscrewing adjustment screws A and B and move up and down, re-tighten when completed.
- 4 Close door and check locking operation of sliding door lock. Difficulty in operation may result from Slamstop button not being fully depressed. To correct operation, open door and turn anti-clockwise strike adjustment screws A and B by one quarter turn, now complete by turning strike adjustment screw C anti-clockwise by one quarter turn. Check lock operation and repeat strike adjustments steps as required.

Note: Care must be taken with adjustments to ensure the striker plate is not bent by applying excessive force