

# Omnia Smart Lock

## INSTALLATION INSTRUCTIONS

### Box contents

#### Spindle, choose one set:

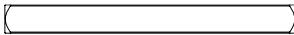

Straight through spindle 45 - 60mm doors

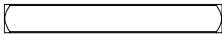

Straight through spindle 35 - 45mm doors



Split spindle 45 - 60mm doors



Split spindle 35 - 45mm doors



\* Springs for use with split spindle only



\* Spindle locking bar for use with straight through spindle only



Hexagonal screw casings

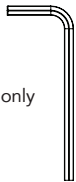

Hex key

#### Fixing screws, choose one set:



55 - 60mm doors



50 - 55mm doors



45 - 50mm doors



40 - 45mm doors



35 - 40mm doors

### Recommended lock

- Legge 991MF or 990MF mortice lock

### Door thickness

- 35mm to 60mm

### Tools required

- Tape measure
- Pencil
- Level
- Drill
- Drill bit - 10mm
- Spade bit - 22mm
- Hammer
- Chisel
- Screwdriver (Phillips)



Scan here for more information on installing the Schlage Omnia Smart Lock

## 1. PREPARING THE DOOR

After preparing the mortice lock as per the instructions of the lock, drill a spindle hole  $\text{\O}22\text{mm}$ . From the centre of spindle hole, measure a top fixing hole at 160mm and a bottom fixing hole at 85mm, drill  $\text{\O}10\text{mm}$  fixing holes. Install mortice lock.

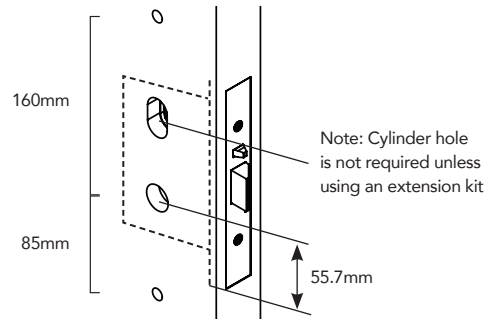

## 2. FASTEN HEXAGONAL POSTS

Attach the hexagonal screw casings to the studs on the back of the external unit.

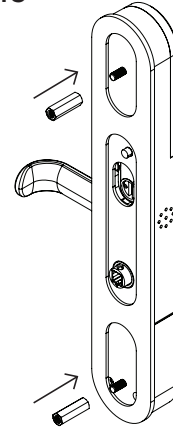

## 3. HANDING – EXTERNAL UNIT (AS REQUIRED)

Using a hex key, remove the holding screw from the lever. Remove the lever, rotate the lever 180° and reattach the lever. Reinstall the securing screw and tighten.

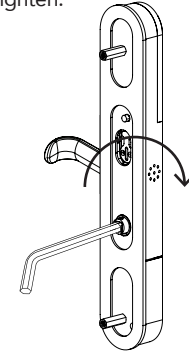

## 4. HANDING – INTERNAL UNIT (AS REQUIRED)

Use a screw driver to remove securing screws. Remove the lever, rotate the lever 180° and reattach the lever. Refasten the securing screws.

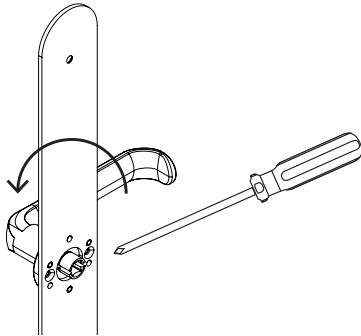

## 5. ADJUST SPINDLE HOLDER DIRECTION

Ensure the spindle holder arrow points in the opposite direction of the lever when using a mortice lock. When using a latch, ensure the arrow points down.

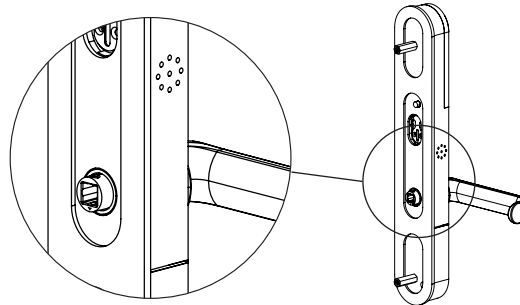

## 6. SELECT CORRECT LENGTH SCREWS AND SPINDLE

Refer to the front cover for box contents, to select the correct screws and spindles to suit your door thickness.

Spindle, choose one set:

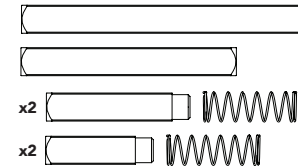

Fixing screws, choose one set:

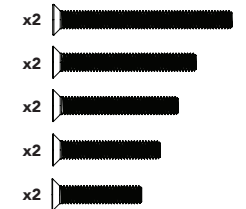

## 7. FASTEN EXTERNAL AND INTERNAL UNITS TO DOOR

Fasten units to the door, ensuring gasket is seated correctly.

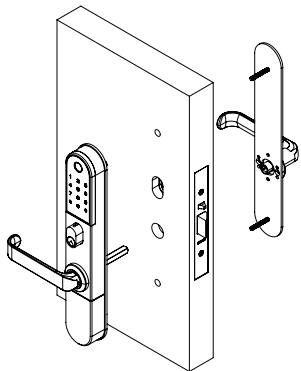

## 8. INSTALL BATTERIES

Use a screwdriver to remove the battery cover. Install 4x AAA alkaline batteries. Resecure the battery cover.

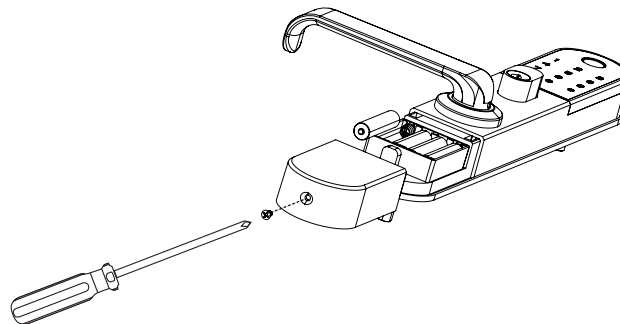

## 9. TEST OPERATION

Rotate the external lever, ensure latch bolt does not retract (refer to step 5). Rotate the internal lever, ensure latch bolt does retract (refer to step 6). Test operation using code 123456#. Ignore Bluetooth administrator voice message when testing code.

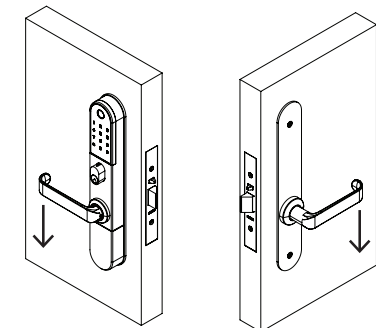

## CARE AND MAINTENANCE

### Door Furniture

At twelve (12) monthly intervals, the fixing screws securing the furniture to the door, both surface fix and through fix, should be checked and tightened as required. Loose fitting furniture which fails will not be covered under warranty.

All door furniture should only be wiped clean with a soft damp cloth. A non-abrasive mild household detergent may be used to remove ingrained grime.

### Mortice Lock

Care should be taken to ensure the internal components are kept free of dirt and woodchips during installation as this is the most common cause of malfunction and will not be covered under warranty. Tubular latches used in external situations should be lubricated by an aerosol lubricant at twelve (12) monthly intervals.

## WARRANTY

Our goods come with guarantees that cannot be excluded under the local consumer law. You are entitled to have the goods repaired or replaced if the goods fail to be of acceptable quality and the failure does not amount to a major failure. The warranty does not cover any defect or damage which may be caused or partly caused if the goods are not properly maintained, installed or are not suitable to the specified application.

Refer to our website for our finish warranty [www.allegion.co.nz/finisheswarranty](http://www.allegion.co.nz/finisheswarranty).

## SCHLAGE BREEZE APP

For an enhanced experience and additional functionality, we recommend you download the Schlage Breeze mobile app from the Apple App Store or the Google Play Store.

1. Create a user account using your email address (or login if you have an existing account).
2. Ensure Bluetooth is enabled on your phone, tap the keypad of your Schlage Omnia lock to activate it.
3. To pair the lock with the app, click on the + and follow the instructions on the app.

Allegion (Australia) Pty Ltd  
Freephone 1800 098 094  
Email [info.au@allegion.com](mailto:info.au@allegion.com)  
[www.allegion.com.au](http://www.allegion.com.au)

Allegion (New Zealand) Limited  
Freephone 0800 477 869  
Email [nzinfo@allegion.com](mailto:nzinfo@allegion.com)  
[www.allegion.co.nz](http://www.allegion.co.nz)



©Allegion 2023